

WIDE RANGE INFRARED THERMOMETER

MODEL KTL-PRO/KTL-ZERO

FEATURES

- 1 Wide measuring ranges
- 2 Precision optics with zoom
- 3 On-line or portable use
- 4 Adjustable sampling rate
- 5 2-way LED display of readings
- 6 Analog and digital outputs through the multifunction AC adopter
- 7 Option of wireless communication of measured data through blue tooth



DESCRIPTION

KTL series infrared radiation thermometers are combination of highly durable sensor, reliable microprocessor electronic and precision camera optics. It is provided with four measuring modes Cont/Peak/Valley & Hold. Measured readings are displayed on LED both inside the viewfinder and on side panel of the thermometer. Variable sampling rate can be set from 0.01 to 1.00 seconds allowing fast response or facilitating smooth readout if target temperature is rapidly changing. Analog and digital outputs are available as standard. PC communication software is included as standard accessory.

TYPICAL APPLICATIONS

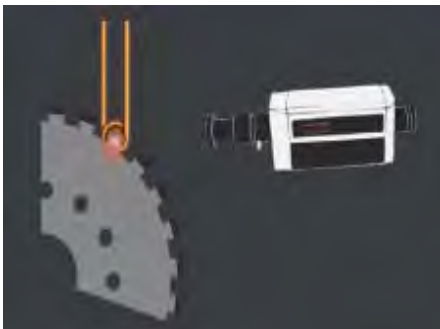

Brazing temperature control for diamond cutter chip



Temperature control with flame raw

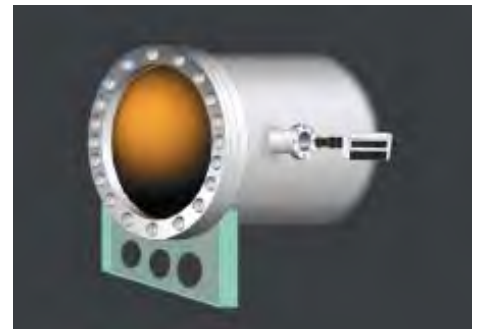

Measurement in vacuum chamber



Control of high-frequency induction heating chip row

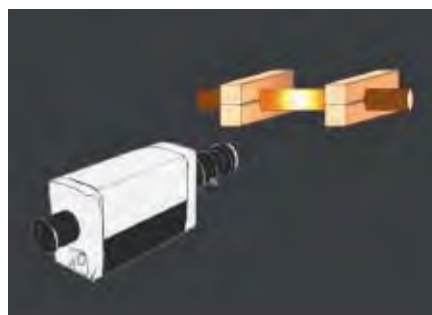

Temperature management of rod stick

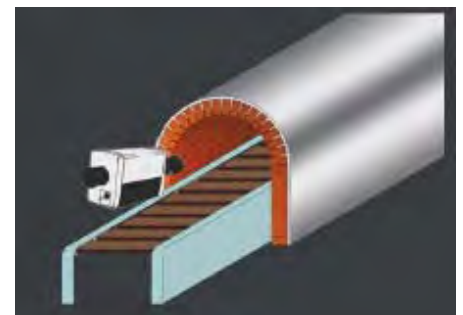

Temperature survey of Furnace and furnace wall

TECHNICAL SPECIFICATIONS

Model	KTL-PRO		KTL-ZERO			
	KTL-PRO	KTL-PRO-04	KTL-ZERO-A	KTL-ZERO-B	KTL-ZERO-A-04	KTL-ZERO-B-04
Temperature range	200~2000°C	300~2000°C	500~3000°C	200~1200°C	700~3000°C	300~1200°C
Display	2-way, 4 digit LED inside the viewfinder and on side panel					
Measuring modes	CONT: continuous PEAK: Max. value display(2 way) VALLEY: Minimum value display(2 way) HOLD: Hold					
Measurement Accuracy	± 1% (at emissivity =1.00)					
Repeatability	± 0.1°C (at emissivity = 1.00)					
Emissivity setup range	0.10 to 1.00 Digital 2 way					
Response time	Sampling time: Adjustable from 0.01 to 1.0 seconds					
Sensor	InGaAs		Si	InGaAs	Si	InGaAs
Spectral response	1.6 μm		0.9 μm	1.6 μm	0.9 μm	1.6 μm
Outputs	3 default output: RS 232C/DC 0~10 V/ DC4~20mA Option: Bluetooth					
Optical system	Model: Coaxial single-lens reflex Field lens: f=127mm, F=4.2 Focal point adjustable range: 270mm~∞ Measured angle: 0.45° Finder: View angle=6.2°					
Active power supply	AC 100~230V 50/60Hz (Supplied by AC adaptor)					
Power consumption	30W (Supplied by AC adaptor)					
Tolerance temperature	0~50°C (Without dew drop)					
Weight	1.4 Kg (Main unit only)					

SPOT SIZE DETAILS AND FIELD OF VIEW DATA

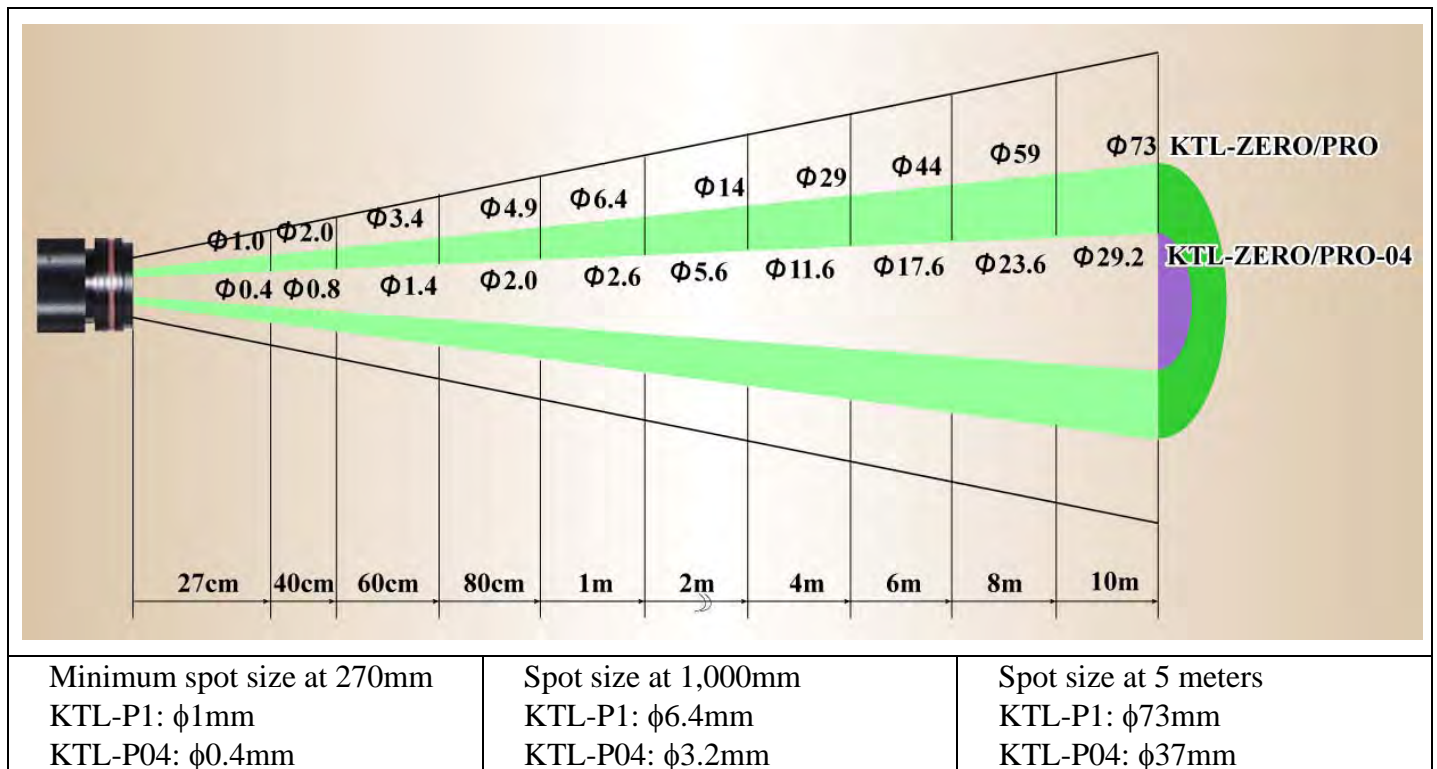

VIEWFINDER DISPLAY

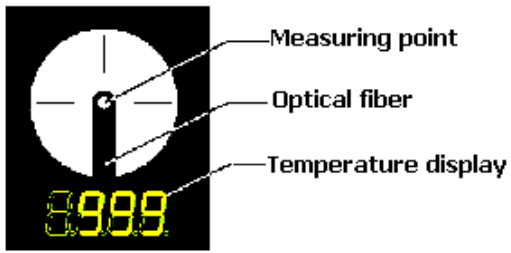

SIDE DISPLAY & FUNCTION KEYS

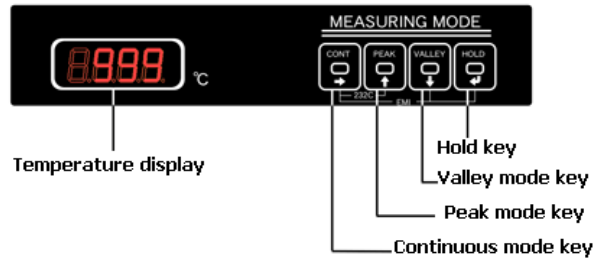

ANALOGUE SCALING SAMPLE

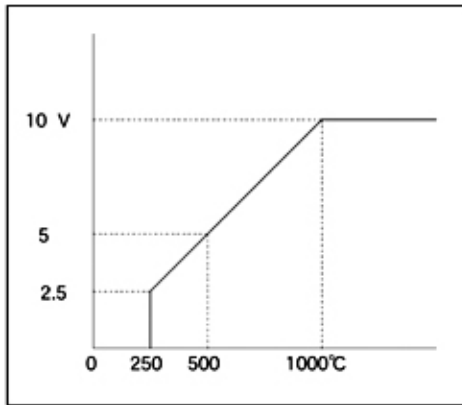

KTL-PRO

4~20mA scaled to 500~1500°C

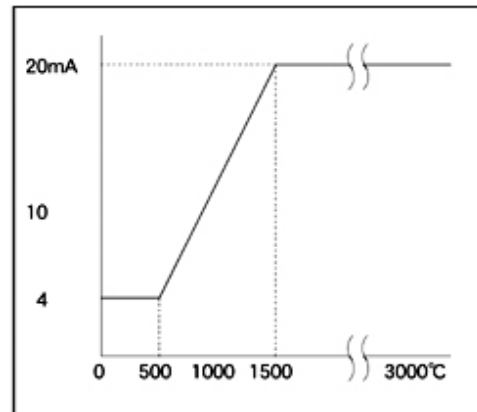

KTL-ZERO

0~10V scaled to 0(250)~1000°C

DIMENSIONS (mm/not to scale)

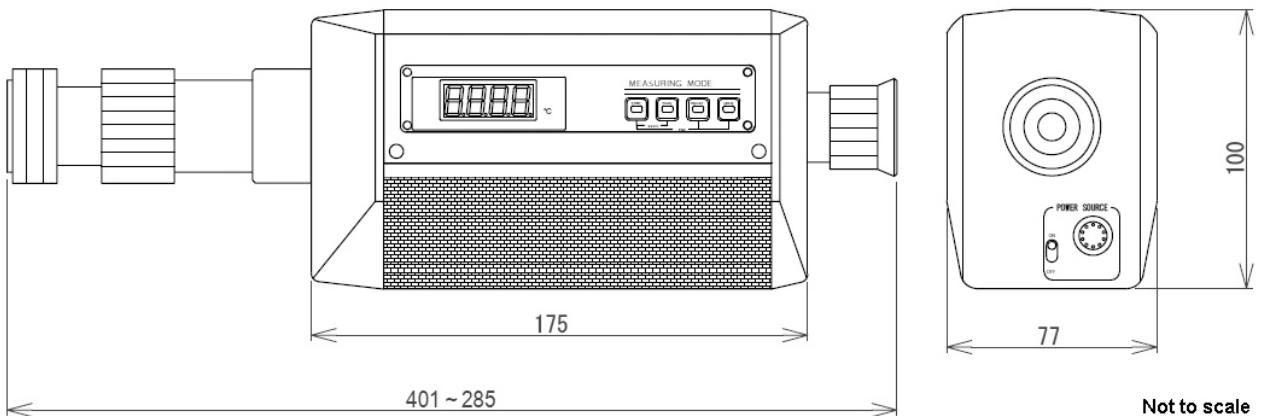

Appearance size

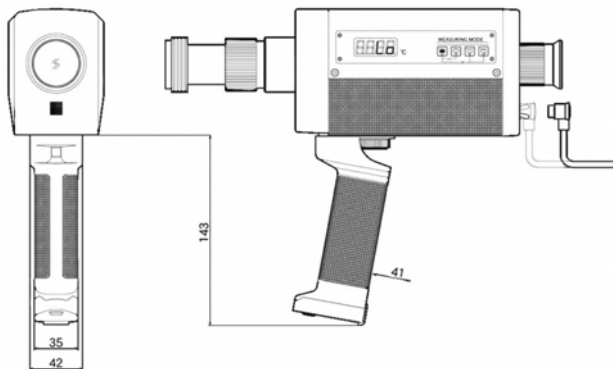

Grip mounting

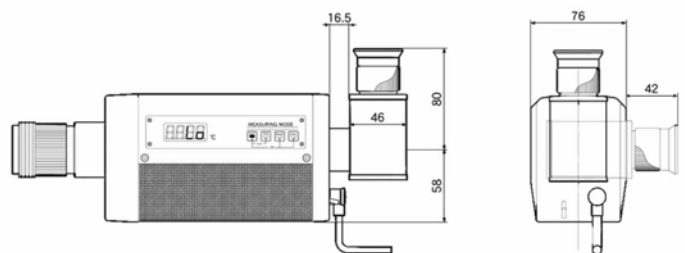

L shape mirror mounting

OPTION & ACCESSORIES

WIRELESS BLUE TOOTH DATA COMMUNICATION

New models KTL-P1-B and KTL-P04-B are capable of communicating measured data to a remote PC using Bluetooth (Version 2.0 + EDR) for high speed wireless data transfer. Distance to remote PC can be 30~40 meters using optional micro USB adopter. Communication distance varies depending on surrounding environment.

Software to collect and display measured data is supplied as standard accessory. Data can be displayed in graphical form and can be read and written in CSV format.



ACCESSORIES

KTL-PRO (basic model)	Pistol grip GL-ST	Pistol grip GL-DX + +charger	USB adapter
Carrying case CK-1	AC adopter PS-5	Right angle mirror LM-1	
Swivel head LA-1B	Swivel head LA-1G	DA converter	
			Tripod SL-68G
Air purge F02-002	Wall mount LA-2	Tripod U-8000	

DUE TO CONTINUOUS PRODUCT IMPROVEMENT, THE DESIGN AND TECHNICAL SPECIFICATIONS ARE SUBJECT TO CHANGE WITHOUT PRIOR NOTICE

TASHIKA BOEKI SHOKAI K.K.

1-12, Kaiyo-cho, Ashiya, 659-0035, JAPAN

Tel: + 81-797-23-9035 Fax: + 81-797-23-2105

e-mail: sales@tashika.co.jp URL: www.tashika.co.jp