

Portable Oxygen Analyzer TB-FI series

What's TB-FI series

Detective element is made of Zirconia electrolyte.
TB-IIF-P sensor and C-101 control unit are installed altogether in a box for portable uses.
This analyzer can be used for every application where range of 1ppm to 100%, but for accurate measurement of high % oxygen, we recommend FG-X series.

Feature

- ◎ Wide range application, from 1ppm to 100%O₂.
- ◎ Built-in multi-filter protects detector from dirt and corrosion.
- ◎ Output range can select freely.
- ◎ Serial communication function is equipped normally.
- ◎ AC85V~260V power supply can be applied.



Specifications

Principle	Zirconia electro-chemical cell	
Structure	SS box, TB-II-P sensor, C-101 control unit, needle valve, flow meter etc.	
Model	TB-FI	Pressurized sample
	TB-FI-P	Sampling pump installed
	TB-FI-PC	Sampling pump and charcoal filter installed
	TB-FI-PR	Sampling pump and charcoal filter and mist-separator installed
Measuring range	1ppm~100%O ₂	
Display	% : 0~99.99%O ₂ ppm : 0~9999ppmO ₂	
Output	D.C. 4~20mA, 0~1V or 0~10V (isolated) F.S. can be set within the range of the above-mentioned display freely. RS232C	
Range change	Auto/Manual	
Initial setting	0~25%O ₂ /0~1000ppmO ₂	
Alarm	Output : Hi/Lo, HHi/Hi or Lo/LLo (each A Point of contact • LCD Display) Failure : Disconnection of Heater, RTD (LCD Display)	
Linearity	Large one either of less than ±1%FS or ±1ppm	
Repeatability	Large one either of less than ±1%FS or ±1ppm	
Response	90% reading 10sec. (Swinging to a high density side)	
Drift	Less than ±2%FS/wk	
Piping	Rc1/4	
Sample Flow Rate	0.2~2L/min	
Sample Temp.	300°C MAX.	
Sample pressure	Others 203kPa~1.33×10 ⁻¹ Pa (2atm~10 ⁻³ Torr)	
Warm up time	About 20 minutes	
AC Power	AC85V~AC260V	
Accessory	Power supply code	

MODEL

TB-FI

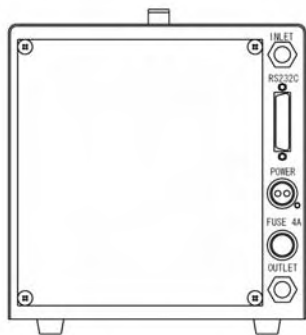
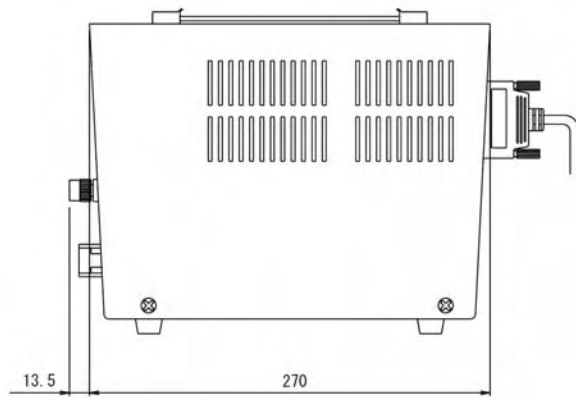
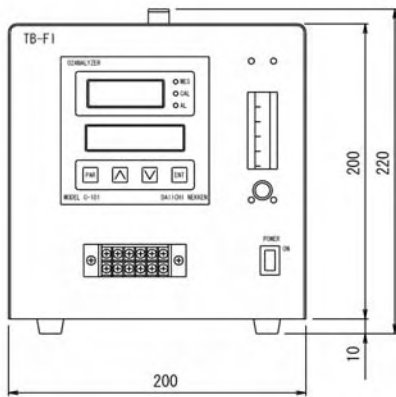

Flow Diagram

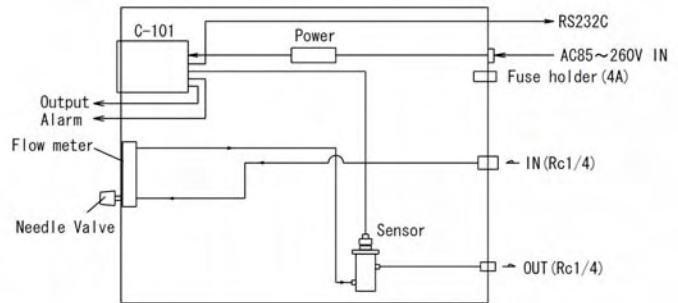

TB-FI-P

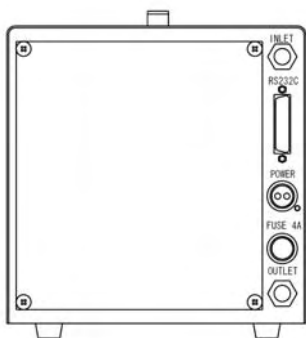
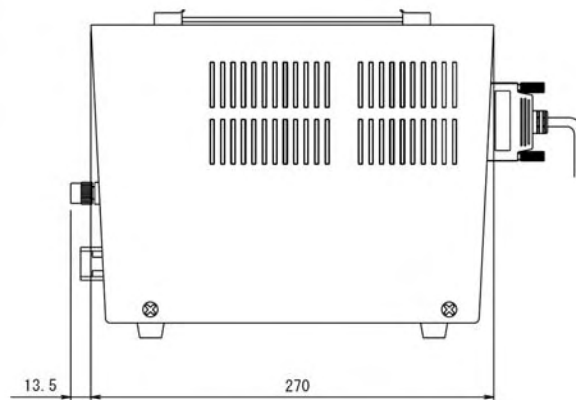
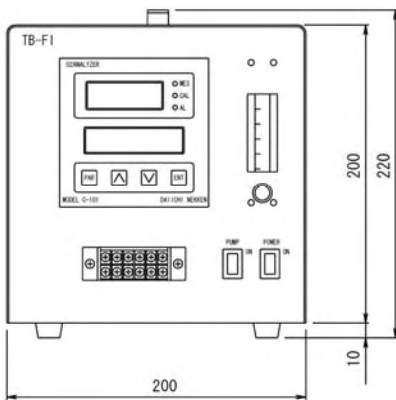

Flow Diagram

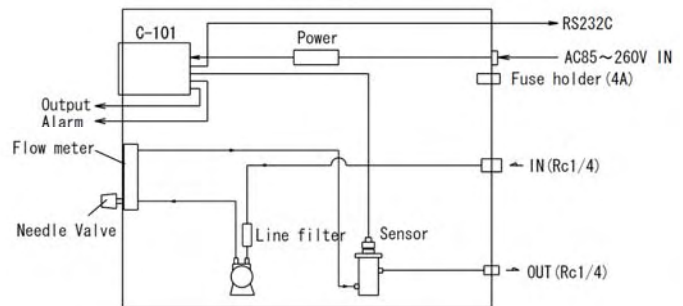

TB-FI-PC

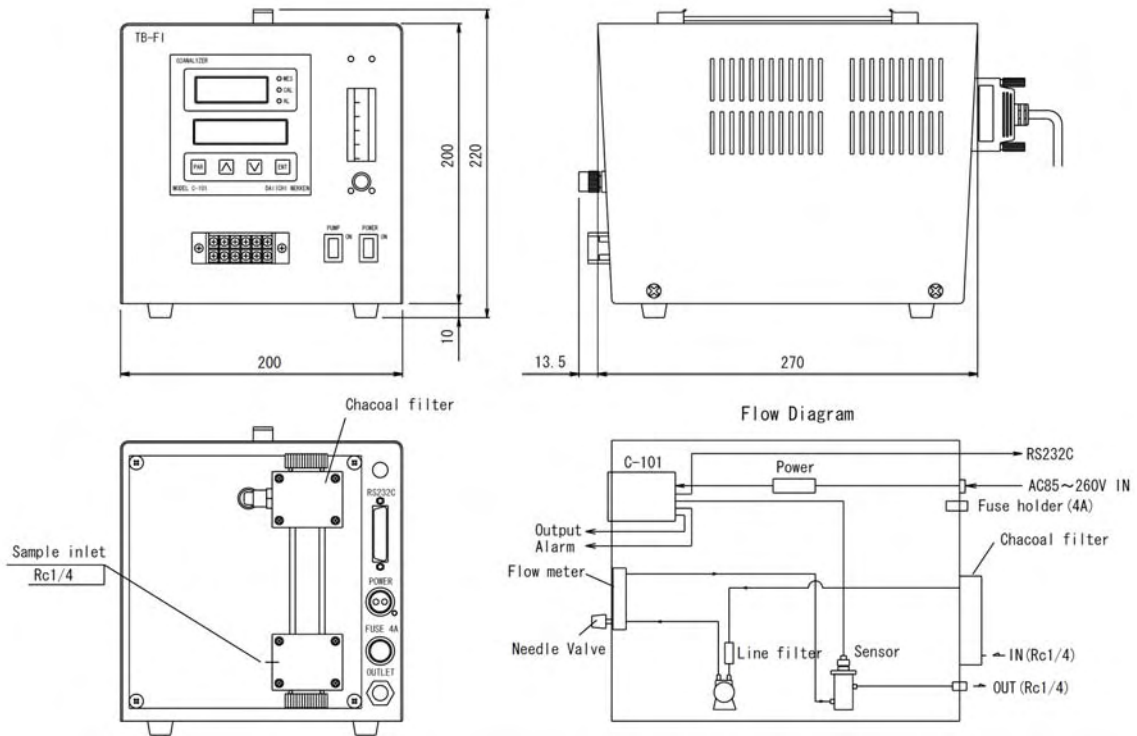

TB-FI-PR

